

Internal structure

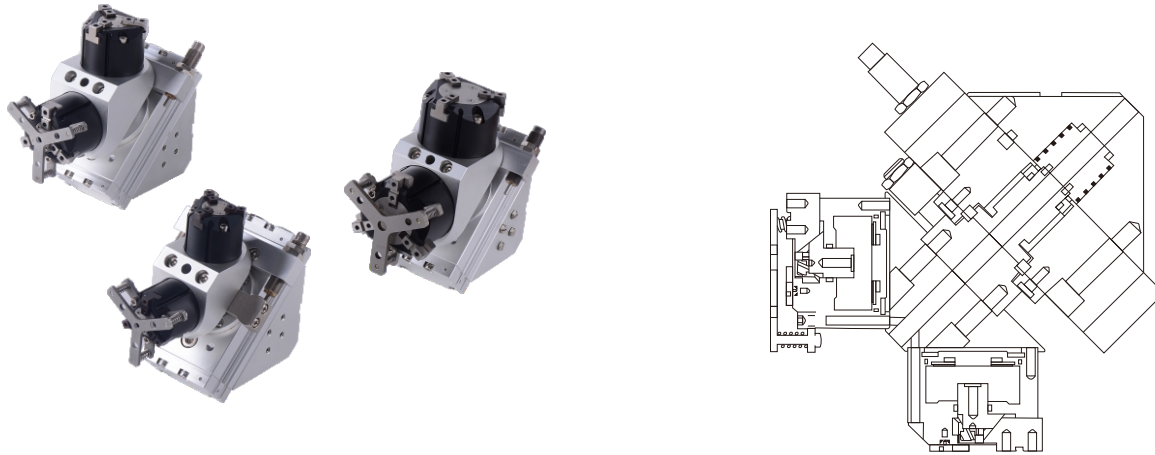

Standard Specifications

Item	Bore size(mm)	20			50		100	
Applicable gripper		NMHS3-25D-RML	NMHS3-32D-RML	NMHS3-40D-RML	NMHS3-50D-RML	NMHS3-63D-RML	NMHS3-80D-RML	NMHS3-100D-RML
Operation	Rotary cylinder	Double Acting						
	Gripper	Double Acting						
Gripping force	OPEN(N)	30	70	131	282	446	578	946
	CLOSE(N)	35	82	149	314	496	641	1009
Fluid		Air						
Pressure range Kg/cm2(Kpa)		1.5-7 (150-170)						
Max. operating pressure Kg/cm2(Kpa)		6.5 (650)						
Ambient and fluid temperature °C		0-60						
Lubrication		Free						
Gripping force		M5			PT 1/8 "			
		M5				PT 1/8 "		
Cushion type to rotary cylinder		Shock absorber						

Standard Specifications

NRML

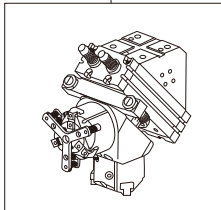

NRML Series- Reversing clamping cylinder

20

Rotary cylinder torque

20-2.2N.m
50-5.5N.m
100-9.8N.m

50

Gripper bore size

25-Φ25mm
32-Φ32mm
40-Φ40mm
50-Φ50mm
63-Φ63mm
80-Φ80mm
100-Φ100mm

Matching specifications:
NRML20: Φ25,Φ32,Φ40
NRML50: Φ50,Φ63
NRML100: Φ80,Φ100

3

2-fingers cylinder

3-fingers cylinder

4-fingers cylinder

SD 2

Sensor switch

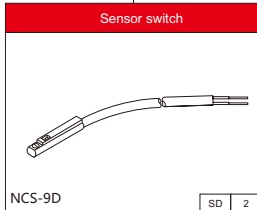

NCS-9D

SD 2

Nil: Without sensor
SD: Symbol of sensors(NCS-9D)
SD: Symbol of sensors(NCS-9B)
2: Number of sensors
1=Sensor 1 pcs
2=Sensor 2 pcs
※The total number of sensor device is 6 pcs
Detour control:2 pcs
Grasp control:4 pcs

Internal structure

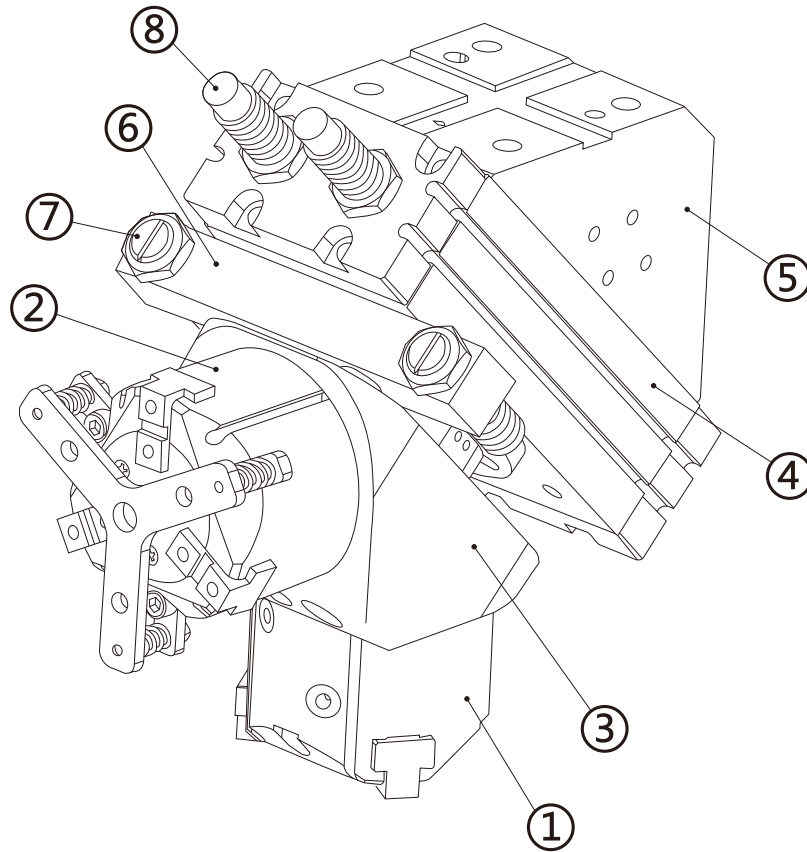

No.	1	2	3	4	5	6	7	8
Model	Gripper	Gripper	Gripper sub-base	Rotary cylinder	Base	Screw sub-base	Adjustment bolt	Shock absorber
NRML20-25-3	NMHS3-25D-RML	NMHS3-25D-RML	NRML20-25	NMSQB-20A	NRML20	NRML20	M10x1.0P	NSAC1008-N
NRML20-32-3	NMHS3-32D-RML	NMHS3-32D-RML	NRML20-32					
NRML20-40-3	NMHS3-40D-RML	NMHS3-40D-RML	NRML20-40					
NRML50-50-3	NMHS3-50D-RML	NMHS3-50D-RML	NRML50-50	NMSQB-50A	NRML50	NRML50	M14x1.5P	NSAC1408-N
NRML50-63-3	NMHS3-63D-RML	NMHS3-63D-RML	NRML50-63					
NRML100-80-3	NMHS3-80D-RML	NMHS3-80D-RML	NRML100-80	NMSQB-100A	NRML100	NRML100	M20x1.5P	NSAC2020-N
NRML100-100-3	NMHS3-100D-RML	NMHS3-100D-RML	NRML100-100					

Dimensions

NRML 20-25

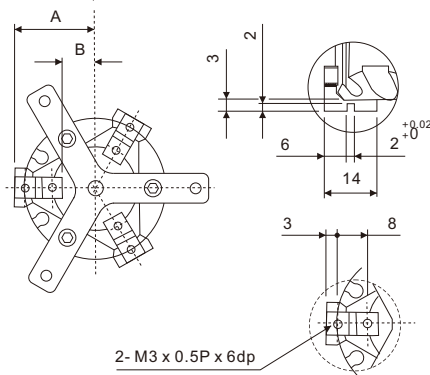
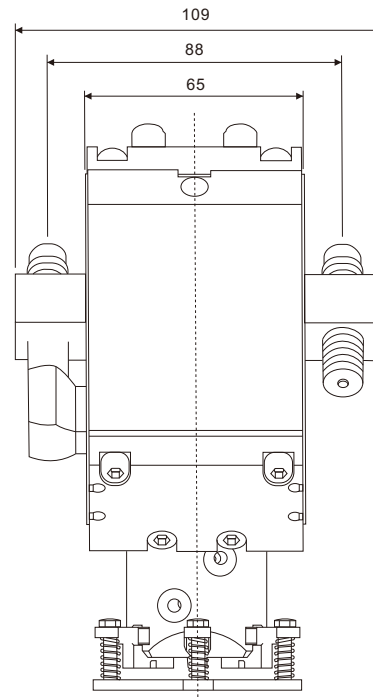
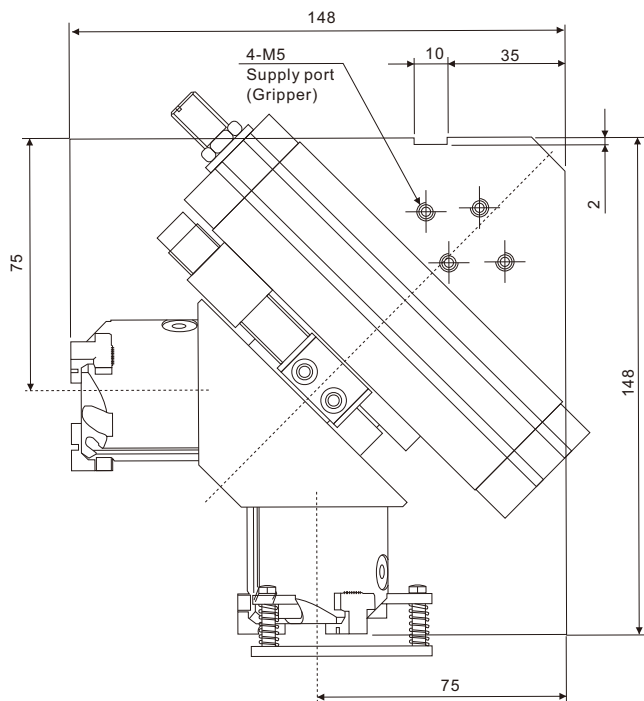
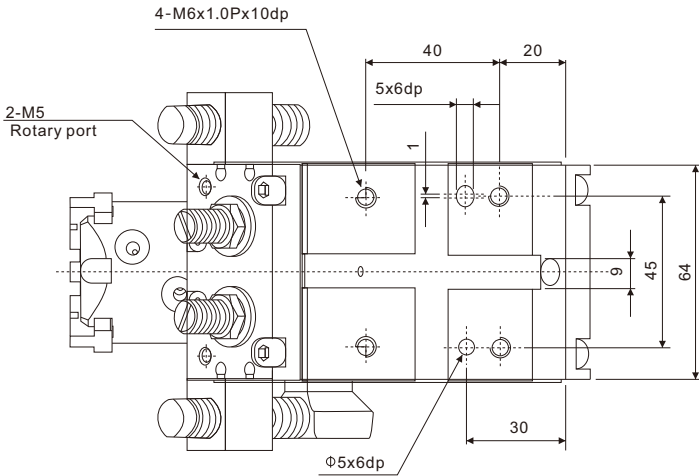

Gripper series	Gripper open/close		
	NMHS3-25D	A	Close:21
	B	Close:7	Open:10

Dimensions

NRML 20-32

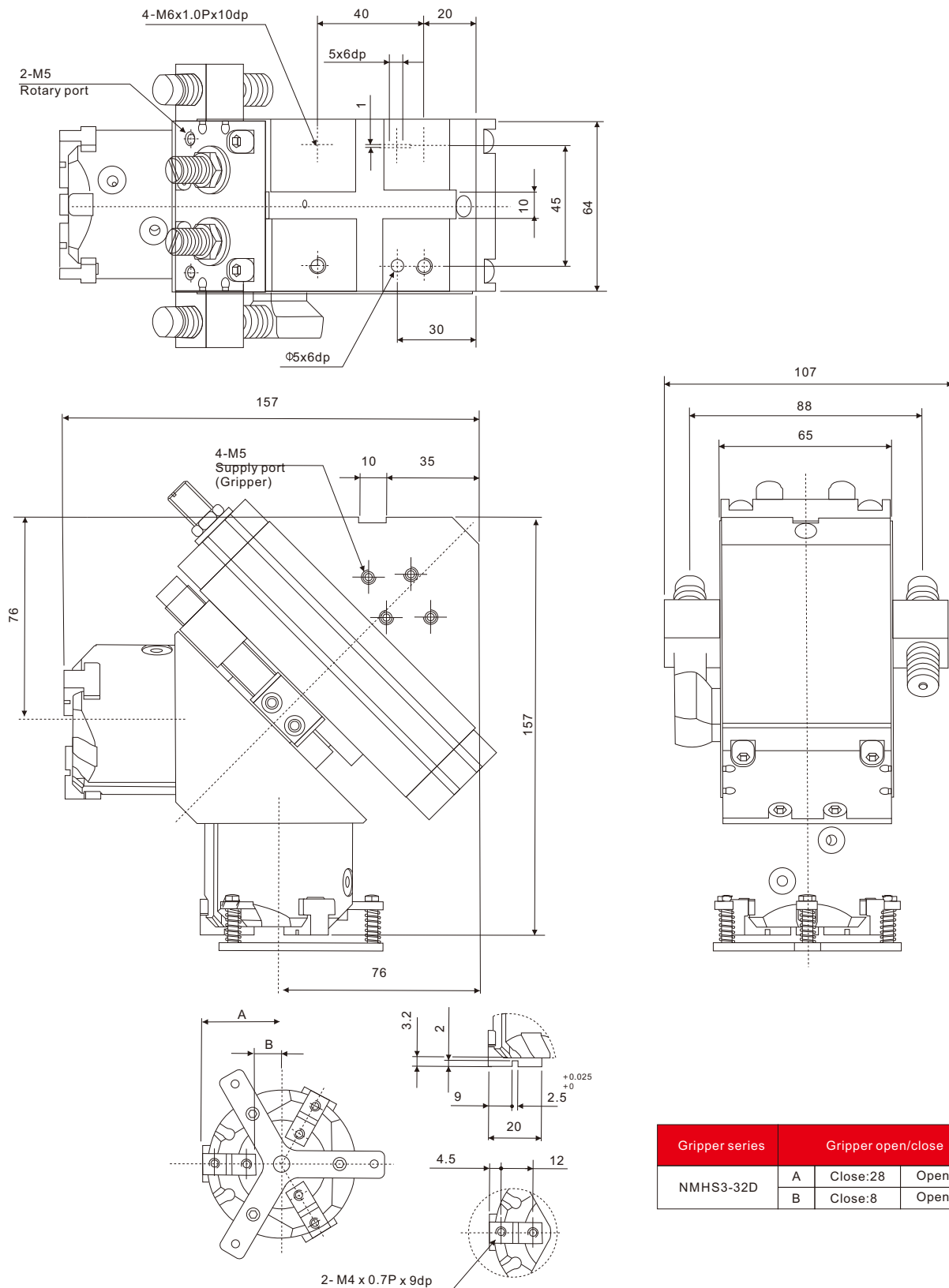

Gripper series	Gripper open/close	
NMHS3-32D	A	Close:28 Open:32
	B	Close:8 Open:12

Dimensions

NRML 20-40

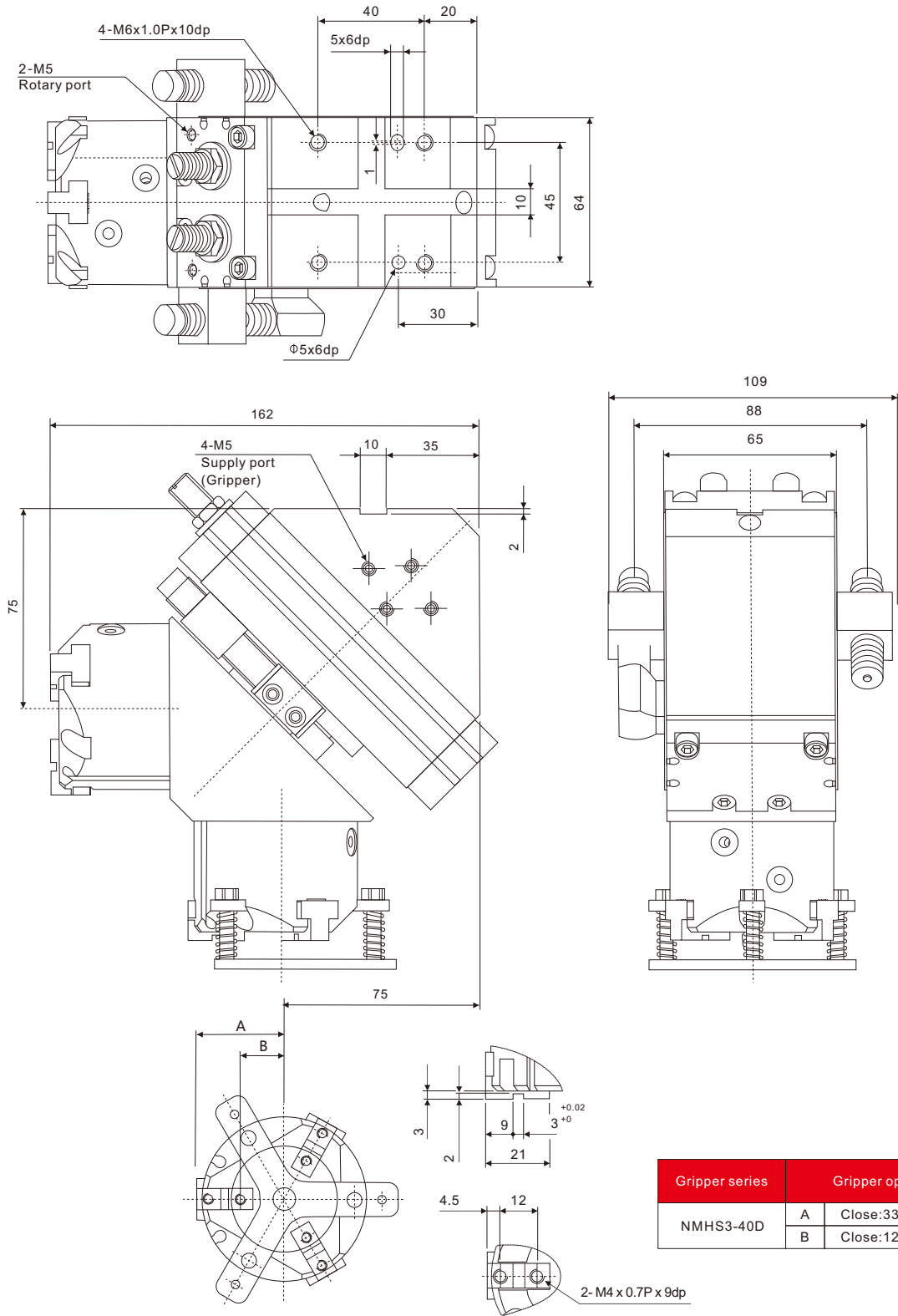

Dimensions

NRML 50-50

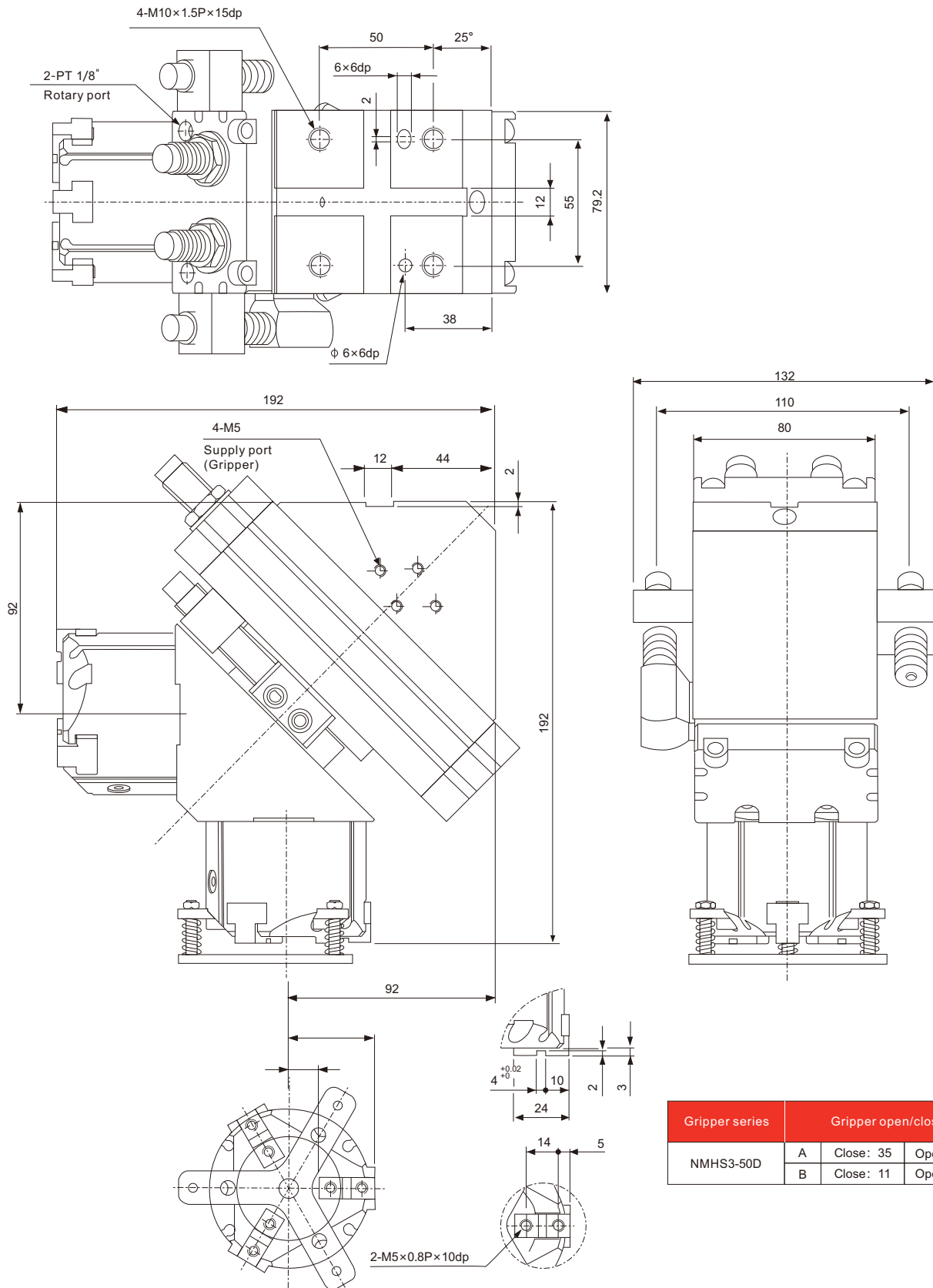

Dimensions

NRML 50-63

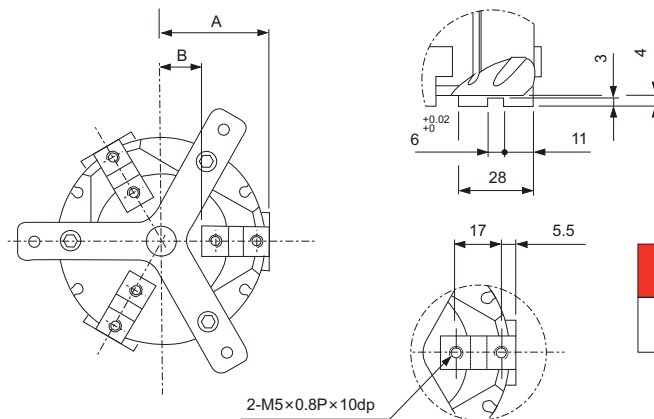
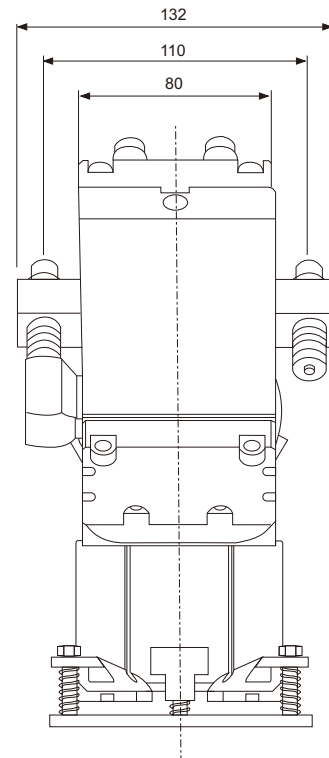
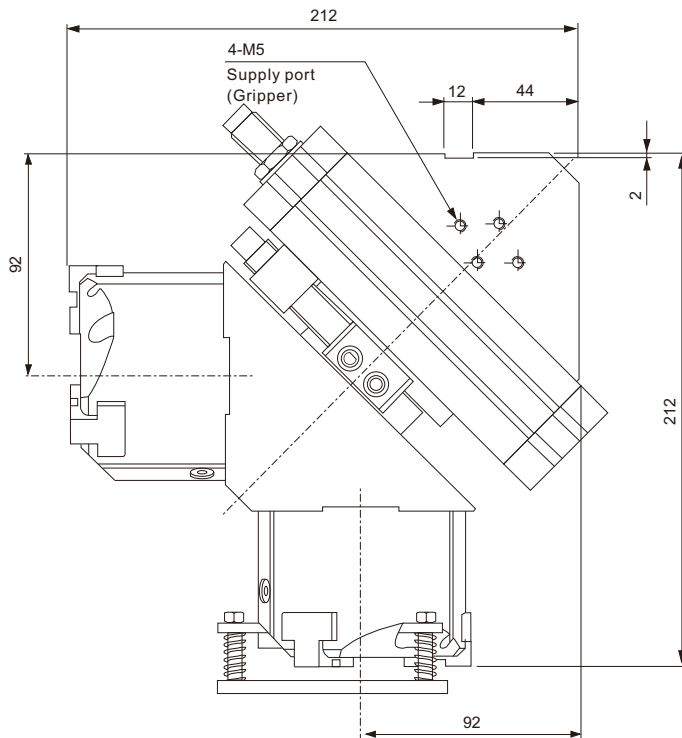
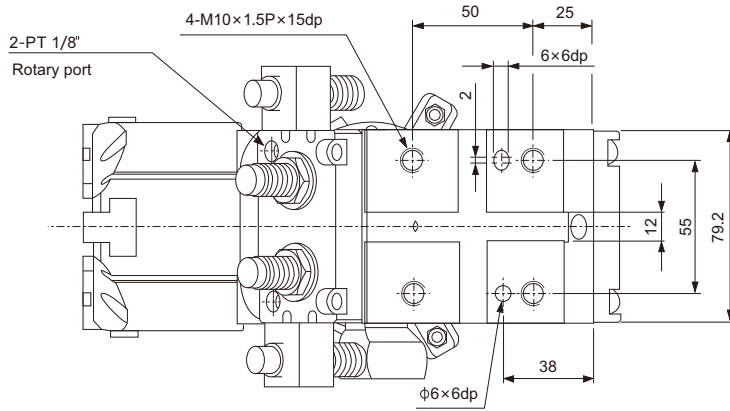

Gripper series	Gripper open/close	
NMHS3-63D	A	Close: 45.5 Open: 53.5
	B	Close: 17.5 Open: 25.5

Dimensions

NRML 100-80

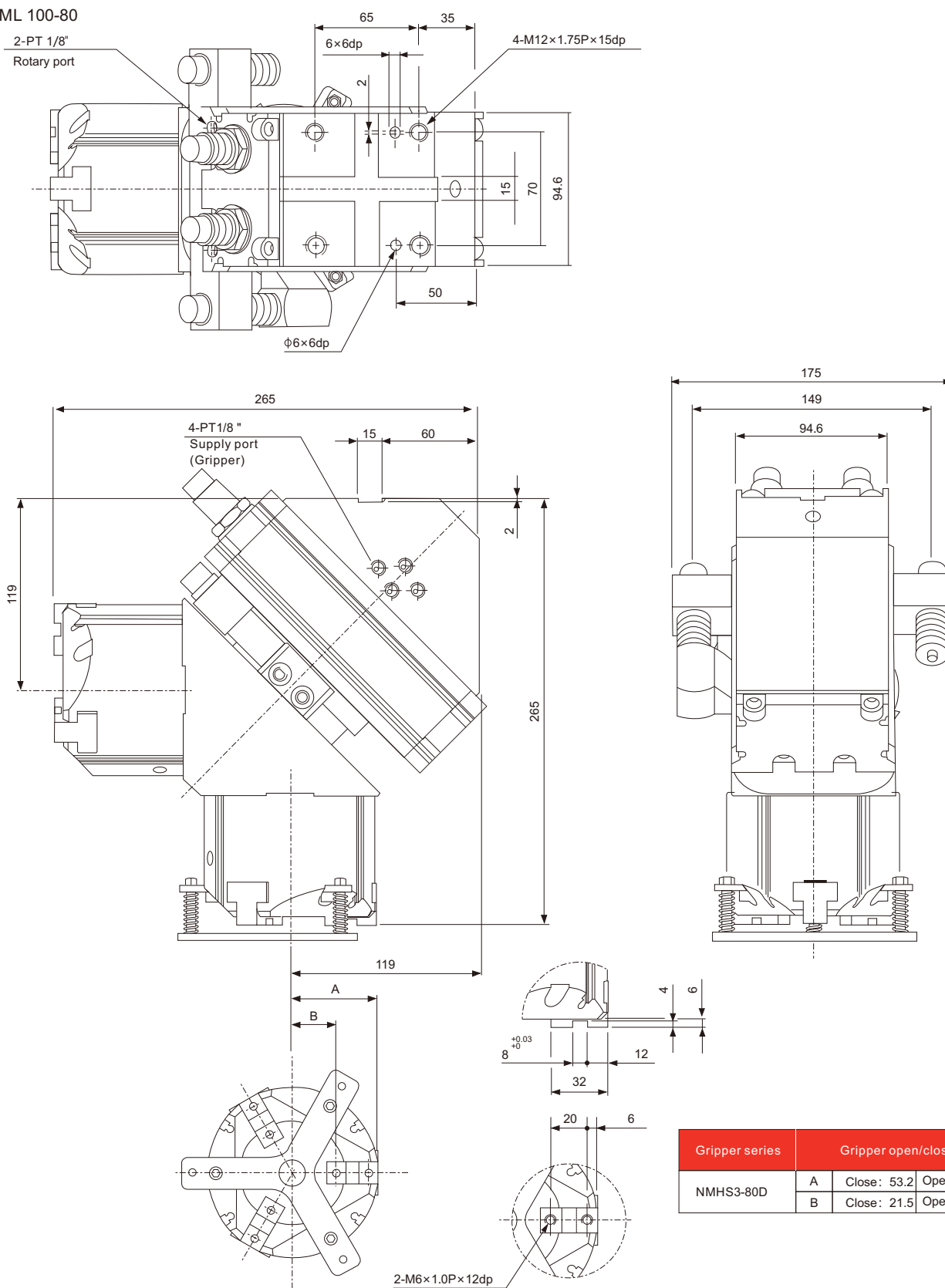

Gripper series	Gripper open/close	
	NMHS3-80D	A Close: 53.2
	B Close: 21.5	Open: 31.5

Dimensions

NRML 100-100

